

No.	ΠΕΡΙΓΡΑΦΗ	ΠΟΣ.
1	Water Outlet Joint	1
2	Spring 0.6×10.5×4.5×12	1
3	O-ring 22×2.4	1
4	Blocking	1
5	O-Ring 5×1.8	1
6	Valve Core	1
7	Valve Core Spring	1
8	Jacket	1
9	O-Ring 4.5×1.8	1
10	O-Ring 16×2.4	1
11	Piston	1
12	Piston Spring	1
13	Piston Seat	1
14	O-Ring 5.6×1.8	1
15	O-Ring 12×1.8	1
16	Valve Seat	1
17	Pump Head	1
18	Screw Internal Hexagonal M6×25	2
19	Spring Gasket 6	3
20	Screw Internal Hexagonal M6×35	1
21	O-Ring 18×2.4	1
22	Water Inlet Joint	1
23	Filter	1
24	Push Rod For Pressure Switch	1
25	Spring Of Push Rod	1
26	Gasket for Connecting Nut	1
27	Y-Ring 4×11×2.5	1
28	O-ring 22×1.9	1
29	Connecting Nut	1
30	Cover Of Pressure Switch	1
31	Microswitch	1

No.	ΠΕΡΙΓΡΑΦΗ	ΠΟΣ.
32	Screw Internal Hexagona M6×30	4
33	Spring Gasket6	4
34	Pump Body	1
35	O-Ring 58×2.65	1
36	O-Ring 10×1.5	6
37	Inlet&Outlet Valve Seat	6
38	Inlet&Outlet Valve Core	6
39	Inlet&Outlet Valve	6
40	Inlet&Outlet Valve Spring	6
41	O-Ring 12×1.9	6
42	Inlet &Outlet Valve Cap	6
43	Y-Ring 12×20×5	3
44	O-Ring 24×1.9	3
45	Middle Set	3
46	O-Ring 16×1.9	3
47	In The Interval Set	3
48	Skeleton Sea12×20×4	3
49	Plunger Spring	3
50	Plunger	3
51	Plunger Clip	3
52	Bearing 51107B	1
53	Screw Internal Hexagonal M8×20	1
54	Bearings Seat	1
55	Bearing 6302	1
56	Reinforced seal	1
57	Connecting Seat	1
58	Gear Shaft	1
59	Gear	1
60	Bearing 629	1
61	O-Ring	1
62	Motor	1

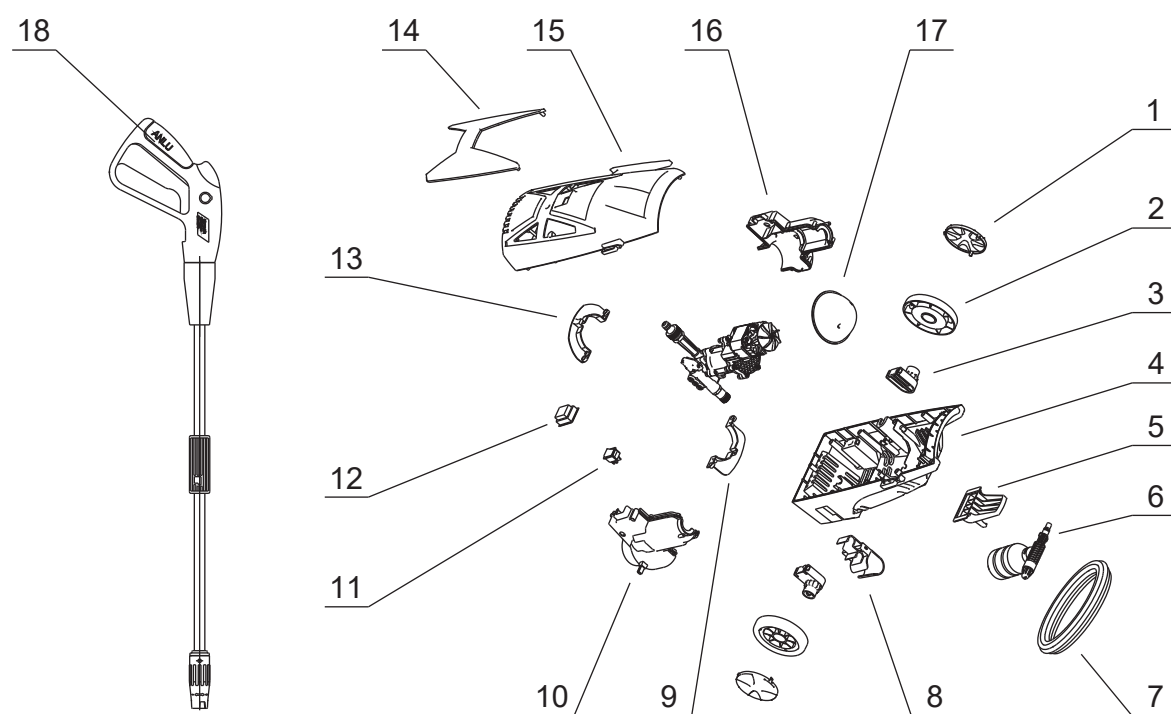

No.	ΠΕΡΙΓΡΑΦΗ	ΠΟΣ.
1	Wheel cover	1
2	Wheel	1
3	Wheel supporter	1
4	Bottom cover	1
5	Hose supporter	
6	Soap bottle	1
7	Hose	1
8	Gun supporter	1
9	Bottom heat insulation plate	1

No.	ΠΕΡΙΓΡΑΦΗ	ΠΟΣ.
10	Motor cover -left	1
11	Switch	1
12	Switch jacket	1
13	Top heat insulation plate	1
14	Decoration plate	1
15	Top cover	1
16	Motor cover - right	1
17	Waterproof cap	1
18	Spray gun	1